



Primary Airfield Lighting Cables

Screened versus Non-Screened

Two different types of cables are used in primary airfield lighting circuits:

- non-screened cables and
- screened cables.

Classically both cables have a single AWG 8 copper conductor or a cross section of 6.0 mm². In most cases, the conductor is equipped with a conductor shield formed by a semi-conductive layer, covered by an XLPE insulation.

Typically the non screened cable has no outer sheath.

The screened version has another semi-conductive layer above the XLPE insulation covered by a metallic screen (braid or metallic foil) and an outer sheath.

Both cables perform well in primary airfield lighting circuits. Nevertheless, the non-screened cable shows a rather high sensitivity to the tracking phenomenon under specific circumstances, leading to service interruption of the lighting circuit.

1. CCR, transformer, lights and cable

The fig. 1 shows a typical primary airfield lighting circuit, where a constant current regulator (CCR) feeds the primary airfield cable, the transformers and the lights.

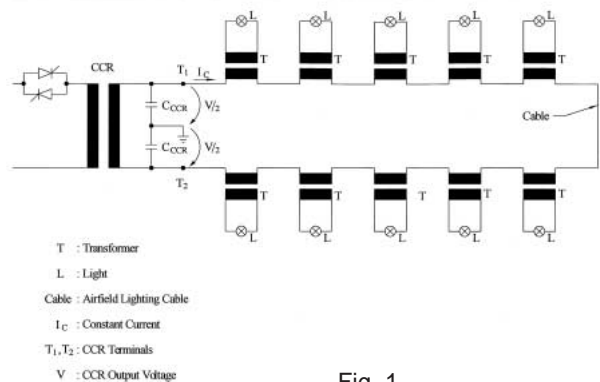

Fig. 1





2. Screened cables

The screen of the cable determines a defined voltage across the dielectric of the cable.

The screen is earthed and the voltage to earth is $V/2$ at the terminals of the CCR, V being the voltage generated by the CCR to draw the preset current I_C .

The transformers and the lights are represented in fig. 2 by their equivalent resistance R_L ,

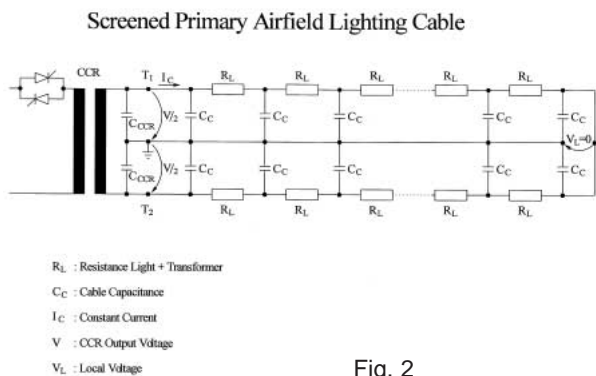

Fig. 2

A voltage drop at each transformer and its light occurs and in case of a balanced circuit as shown in fig. 2. Where the transformers are equally distributed along the cable path, the voltage appearing between conductor and screen is zero at a point situated somewhere in the middle of the circuit.

3. Unscreened cables

The local voltage across the dielectric of unscreened cables is not as well determined as is the case on screened cables. The voltage drop across the transformer terminals and especially the capacitive voltage distribution along the cable path determines the voltage to earth.

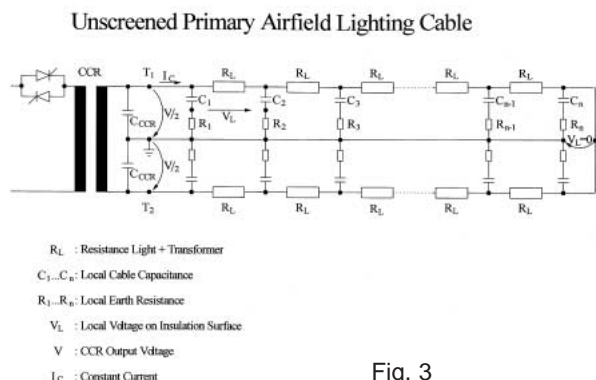

Fig. 3

In proximity of the terminals T1 and T2, the voltage to earth is $V/2$.

Along the cable path the voltage on the dielectric depends on the local earth resistance and the local capacitance of the cable to earth. In places where the cable lays in direct contact with a humid soil, the earth resistance is low and the capacitance is high. The voltage is fully supported by the insulation. The voltage-to-earth appearing in those places across the outer surface of the dielectric is very low. In other places, where the soil is dry, the resistance to earth is high and the local voltage is distributed between the cable insulation and the soil. The electric potential-to-earth appearing on the surface of the dielectric is high.

If these two circumstances of wet and dry soil appear locally close to each other, a voltage difference V_L is build up along the surface of the dielectric; this is shown schematically in figure 3.

An example illustrates this situation in a very simply manner, as shown in figure 4.

The unscreened cable is placed on a earthed metallic cable-ladder. On the steps, the cable surface has a low resistance to earth; between the steps, the resistance to earth is very high. Thus the electric potential to earth on the surface laying on the steps is zero while the electric potential on the cable surface laying between the steps is high; the voltage across the cable surface and the steps corresponds approximately to the applied voltage, e.g. $V/2$, when this cable ladder is used close to the constant current regulator.

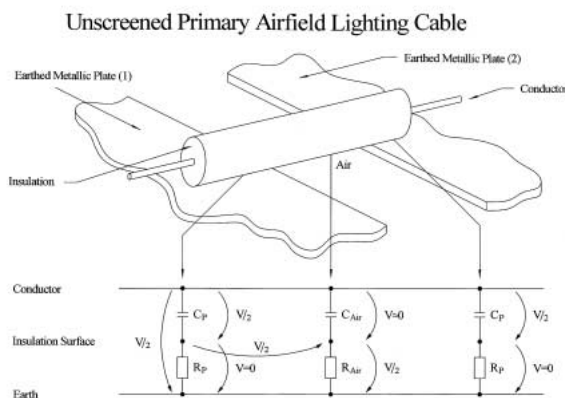

Fig. 4

From a safety point of view the potential difference on the cable surface in such a situation can reach a dangerous level. Additionally there is a risk of surface tracking when the cable surface is wet or dirty.



4. Unscreened cable placed on or over a metallic plate

Fig. 5 shows an unscreened cable placed at a height h over an earthed metallic plate.

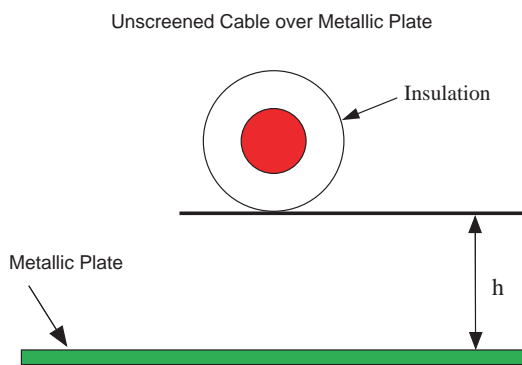

Fig. 5

The electric field is unequally distributed in the cable dielectric and the air between the dielectric and the metallic plate.

The following table gives the maximum electric field strength in that air gap in function of the height h for a unscreened 5 kV – AWG 8 - cable with 2,8 mm XLPE insulation according to FAA Specification L-824. The field is given in kV/mm for a peak voltage of 1 kV conductor to earth.

Height h/mm	E air (peak) kV/mm
0	1,18
0,1	1,10
0,2	0,95
0,5	0,75
1,0	0,58
2,0	0,42

Table 1: Electric field in air gap; conductor to metallic plate voltage is 1 kV

5. Measurements

Voltage measurements have been realised on several 10 kVA CCR with a digital storage oscilloscope. The latter is equipped with one differential input composed by one inverting and one non-inverting input; both inputs are fitted with HV-probes; the oscilloscope is earthed.

Fig. 6 shows the voltage of a normally working CCR; the RMS voltage is 1,23 kV; the peak voltage to earth 2,12 kV.

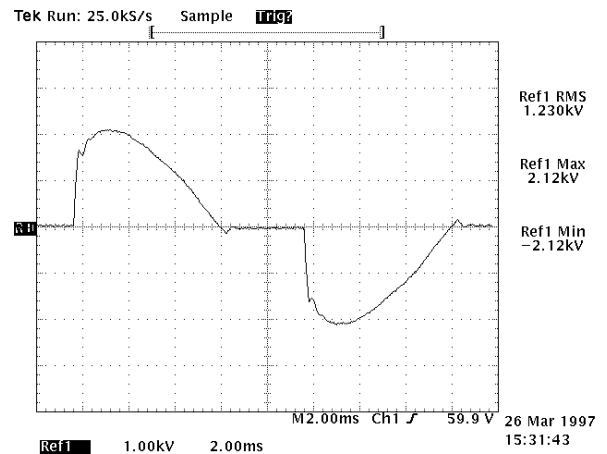

Fig. 6: CCR voltage to earth under normal condition

Fig. 7 shows the voltage of a circuit, where several lights were blown out. In this case, the cores of the transformers of these lights go into magnetic saturation and the CCR therefore delivers a much higher peak voltage.

Under these circumstances the measured peak voltage is 2,72 kVp to earth.

6. Risk of tracking discharges

If the unscreened cable is laying on a metallic plate, the field in the air gap between the cable and the plate will be for $h = 0,1$ mm and 1 kVp (see table 1):

$$E_{\text{air}} = 1,1 \text{ kV/mm}$$

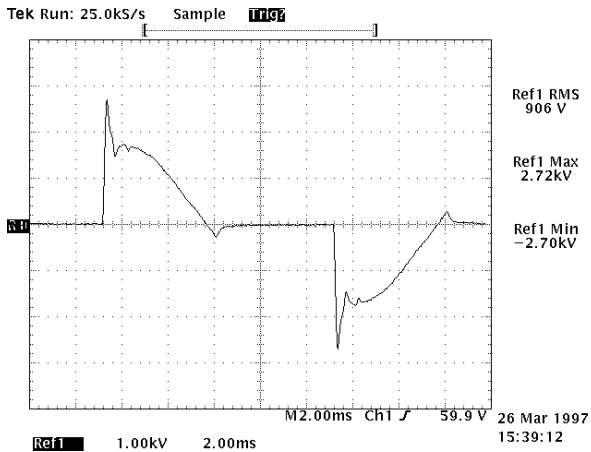

Fig. 7: CCR voltage to earth with blown out lights

At the measured peak voltage of 2.72 kV, the electrical field strength in the air gap will be:
 $E_{air} = 1.1 \cdot 2.72 \text{ kV/mm} = 2.99 \text{ kV/mm}$

This field strength corresponds to the disruptive field strength in air; an electrical discharge starts at each half cycle of the voltage; ozone formation and erosion of the dielectric risk to damage the cable surface by tracking.

7. Recommendations

The described tracking risk doesn't exist with screened cables; also from a safety point of view the use of screened cables is to be preferred.

The risk introduced by the tracking phenomenon is well known and introduced in different standards. The US Standard ICEA-S-66 524, § 4.2.2, applicable to airfield lighting cables, states:

"Shielding should be considered where any of the following conditions exists:

1. connections to aerial lines;
2. transition from conducting to non conducting environment;
3. transition from moist to dry earth;
4. dry soil, such in the desert; or
5. damp conduits."

In the Appendix G "Shielding" of this standard several other provisions are made concerning the use of shielding, especially in § G3.1.3:

"Likewise, damage to non-shielded cable may result when the surface of the cable is moist or covered with soot, soapy grease, or other conducting film and the external field is partly confined by such conducting film so that the charging current is carried by the film to some spot where it can discharge to ground. The resultant intensity of discharge may be sufficient to cause burning of the insulation or jacket."

8. Conclusions

The use of non-screened cables introduces several problems:

- **safety:** the risks of electrical discharges should not be neglected.
- **tracking:** the cable may be damaged and cable failures will provoke more maintenance and repair costs.
- **burning:** under unfavourable circumstances, fire hazard becomes a reality.

The use of screened cables avoids those problems:

- **no safety problems:** the cable jacket may be touched without any risk.
- **no tracking phenomenon:** drastically reduced outages.
- **reduced fire hazard.**
- **costs:** reduced maintenance and repair costs.
- **long lasting investment.**



Kabelwerk | **EUPEN** AG
 cable

Malmedyer Str. 9 • 4700 EUPEN • BELGIUM
 Tel.: +32(0)87/59.70.00 • Fax: +32(0)87/59.71.00
www.eupen.com